



# 6-20KVA Online Tower UPS User Manual

---

---

## IMPORTANT SAFETY INSTRUCTIONS

---



*The battery can present a risk of electrical shock and high short circuit current.*

---

*Following precautions should be observed before replacing the battery.*

- **Wear rubber gloves and boots.**
  - **Remove rings, watches and other metal objects.**
  - **Use tools with insulated handles.**
  - **Do not lay tools or other metal objects on the batteries.**
  - **If the battery is damaged in any way or shows signs of leakage, contact your local representative immediately.**
  - **Do not dispose of batteries in a fire. The batteries may explode.**
  - **Handle, transport and recycle batteries in accordance with local representative**
- 



*Improper use can result in electrical shock or fire. To ensure safety, observe the following precautions:*

- **Turn off and unplug the UPS before cleaning it.**
  - **Clean the UPS with a dry cloth. Do not use liquid or aerosol cleaners.**
  - **Never block or insert any objects into the ventilation holes or other openings of the UPS.**
-

---

---

# CONTENTS

<b>IMPORTANT SAFETY INSTRUCTIONS</b> .....	<b>1</b>
<b>1. Product Description</b> .....	<b>4</b>
1.1 Electromagnetic Compatibility .....	4
1.2 Features.....	4
1.3 Models .....	4
1.4 Appearance.....	5
1.5 System description.....	7
1.6 UPS Working Mode.....	8
1.7 Electrical Specification .....	11
<b>2. Installation</b> .....	<b>13</b>
2.1 Unpacking and Inspection .....	13
2.2 Connect AC Power Cables .....	13
2.3 Connect the long backup time model UPS with the external battery .....	14
2.4 Connect Parallel Cables.....	15
<b>Parallel installation</b> .....	<b>15</b>
2.5 Connect Communication Cables .....	16
<b>3. Controls And Indicators</b> .....	<b>18</b>
3.1 Description of Panel .....	18
3.2 Description of LCD Menu .....	19
<b>3.3 Setting</b> .....	<b>21</b>
<b>4. Operation</b> .....	<b>25</b>
4.1 Operation Mode .....	25
4.2 Parallel Operation .....	25
<b>5. Control and Communication</b> .....	<b>27</b>

---

---

5.1 SNMP Card.....	27
5.2 Dry Contact.....	27
5.3 EPO.....	28
<b>6. Maintenance.....</b>	<b>29</b>
6.1 Battery Maintenance.....	29
6.2 Battery Disposal.....	29
6.3 Battery Replacement Procedures.....	30
6.4 Checking UPS status.....	30
<b>7. Trouble Shooting.....</b>	<b>32</b>
<b><i>Annex A. Parallel Setting.....</i></b>	<b><i>36</i></b>
<b><i>Annex B. Mechanical Dimension.....</i></b>	<b><i>37</i></b>

## 1. Product Description

This chapter gives a brief description of the UPS, including the UPS features, models, appearance, operating principle and specification.

### 1.1 Electromagnetic Compatibility

<b>* Safety</b>	
IEC/EN 62040-1-1	
<b>* EMI</b>	
Conducted Emission.....IEC/EN 62040-2	Category C3
Radiated Emission.....IEC/EN 62040-2	Category C3
<b>*EMS</b>	
ESD.....IEC/EN 61000-4-2	Level 4
RS.....IEC/EN 61000-4-3	Level 3
EFT.....IEC/EN 61000-4-4	Level 4
SURGE.....IEC/EN 61000-4-5	Level 4
Low Frequency Signals.....IEC/EN 61000-2-2	
<b>Warning:</b> This is a product for commercial and industrial application in the second environment-installation restrictions or additional measures may be needed to prevent disturbances.	

### 1.2 Features

The UPS features include:

- Fully digital controlled technology based on DSP to achieve high reliability and power function
- Digitally controlled and intelligent battery management to extend the battery life
- Operation and display with LCD and LED indicators, which can indicate all system information
- Fan speed can be auto conditioned according to the loads, current or working mode
- Digitally controlled charger current and voltage
- Battery capacity management
- Self-aging function enable user to test UPS at customer site without load

### 1.3 Models

Available models are shown as Table1-1:

Table 1- 1: Models

Model	Nominal Power	Model	Nominal Power
6KL	6000VA/6000W	10KL	10000VA/10000W
6KB	6000VA/6000W	10KB	10000VA/10000W
3/1 10KL	10000VA/10000W	3/1 20KL	20000VA/20000W

3/1 15KL	15000VA/15000W		
----------	----------------	--	--

Long back up model (L): no internal batteries, max charger current is 8A, settable. 12A optional.

Standard model (B): include internal batteries, charger current is 1A

#### 1.4 Appearance

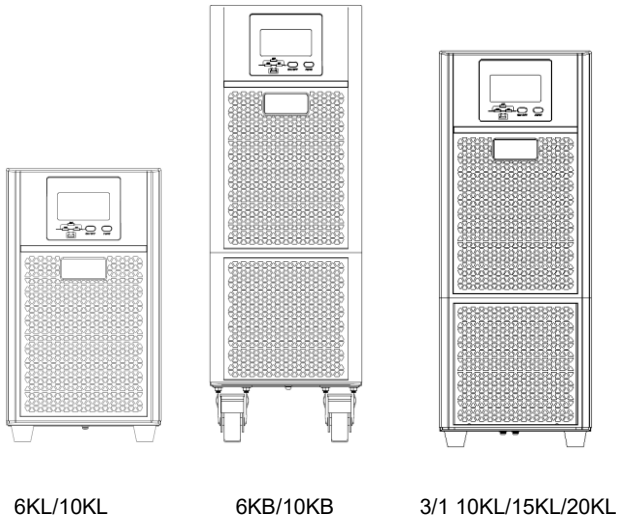
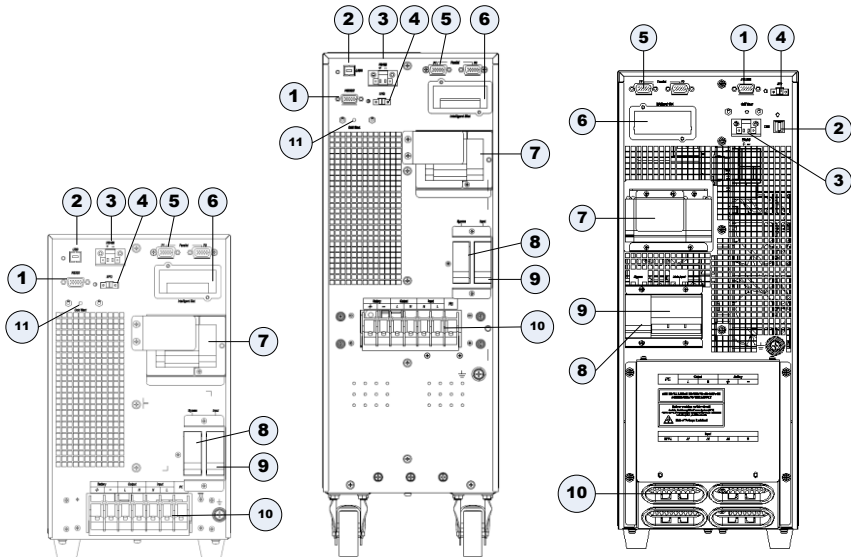

Fig 1- 1: Front View



6KL/10KL

6KB/10KB

3/1 10KL/15KL/20KL

Fig 1- 2: Rear View

1	RS232
2	USB. Optional
3	RS485
4	EPO
5	Parallel ports. Optional
6	Intelligent slot
7	Manual bypass. Optional
8	Bypass breaker
9	Input breaker
10	Connectors: input, output, battery
11	Cold start button

---

---

## 1.5 System description

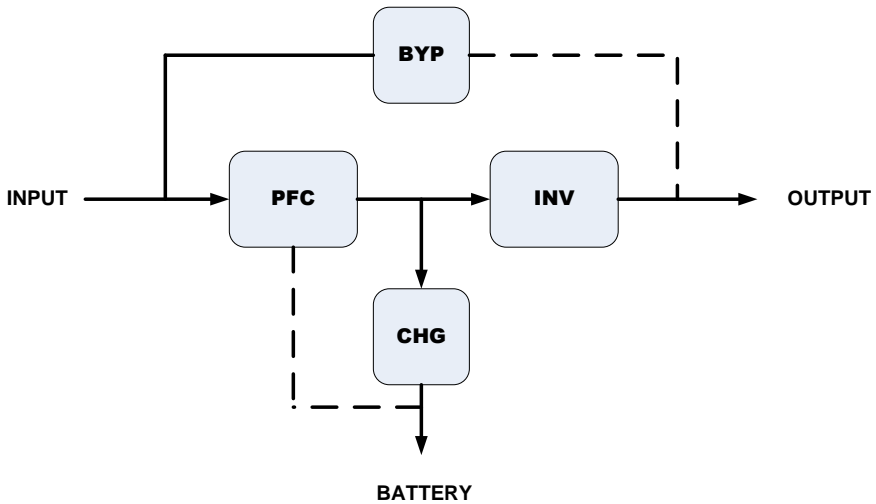

Fig 1- 3: UPS system

### 1.5.1 PFC

In normal operation, PFC converts utility AC power to regulated DC power for use by the inverter. And also, PFC reduces the amount of input current distortion on the utility.

### 1.5.2 Inverter

In normal operation, the inverter converts the DC bus power into precise, regulated sinewave AC power. Upon an utility power failure, the inverter receives energy from the battery.

### 1.5.4 Battery Charger

The battery charger utilizes energy from the DC bus and regulates it to charge the batteries. The batteries are being charged whenever the UPS is connected to utility power.

### 1.5.5 DC/DC Converter

The converter includes boost circuit which is also used as PFC.

---

---

### 1.5.6 Battery

6K/10K Standard models include value-regulated, non-spillable, lead acid batteries inside. To maintain battery design life, operate the UPS in an ambient temperature of 15-25°C.

### 1.5.7 Static Bypass

Static bypass connect utility input and load directly.

### 1.6 UPS Working Mode

UPS working mode include normal mode, bypass mode, battery mode, ECO mode, frequency converter mode, self aging mode.

#### Normal mode:

Shown as *Fig 1-4*, rectifier supply DC supply to inverter, the load is feed by inverter. Charger is charging the battery.

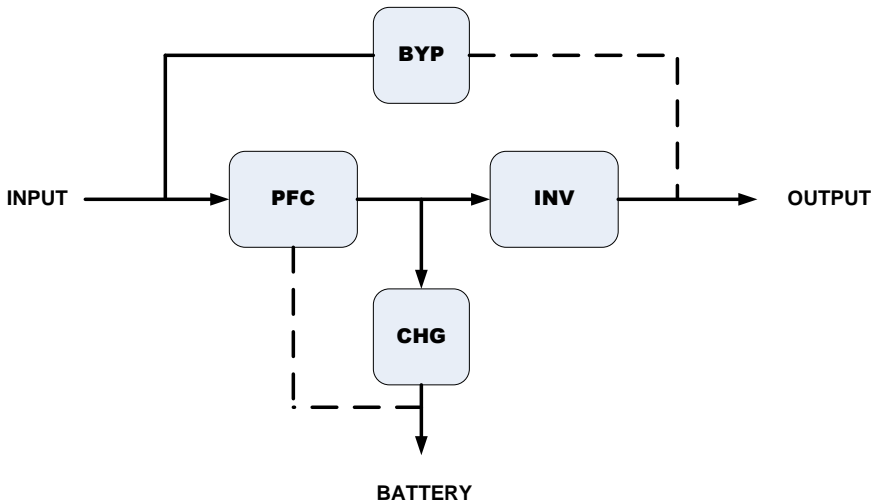

Fig 1- 4: Normal Mode

#### Static Bypass Mode

If inverter is failure or overload, UPS will transfer to bypass mode. Or press ON/OFF to transfer to bypass mode in normal mode. The load is feed by input power directly, and UPS can not protect load from surge. Shown as *Fig 1-5*.

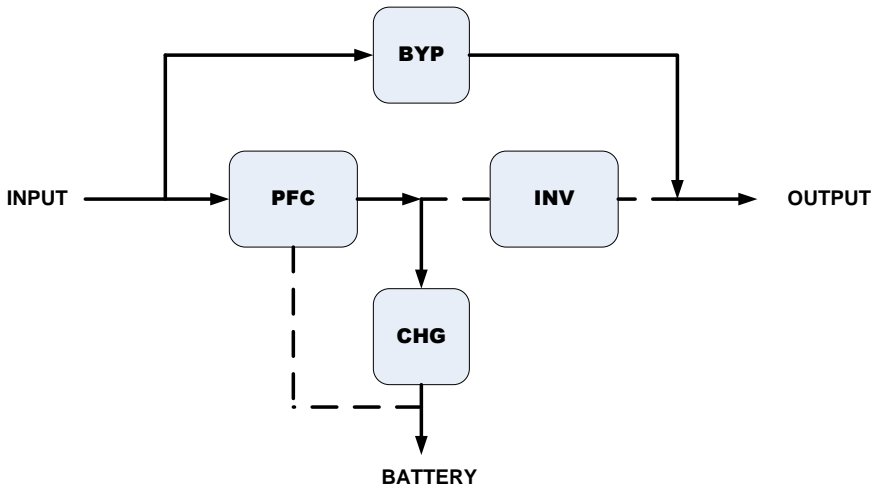

Fig 1- 5: Bypass Mode

**Battery Mode**

If input power is failure when in normal mode, UPS will transfer to battery mode. In this mode, the battery provide power to inverter. Shown as Fig 1-6.

NOTICE: press ON/OFF in battery mode UPS will shutdown completely.

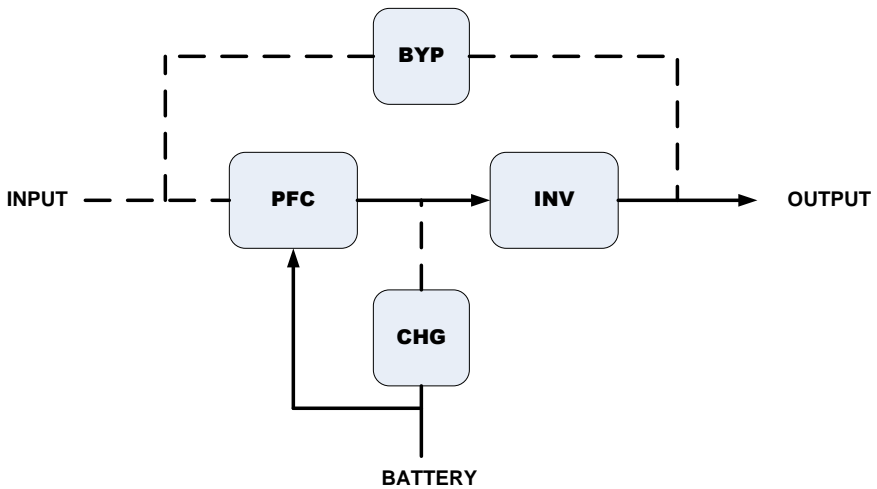

Fig 1- 6: Battery Mode

---

### ECO Mode (only available for single unit)

When UPS works in ECO mode, load is feed by bypass. Inverter is standby, charger is working normally. The efficiency is up to 98%, but UPS can protect the load from surge disturb. If input power is failure, UPS transfer to battery mode. Shown as Fig 1-7.

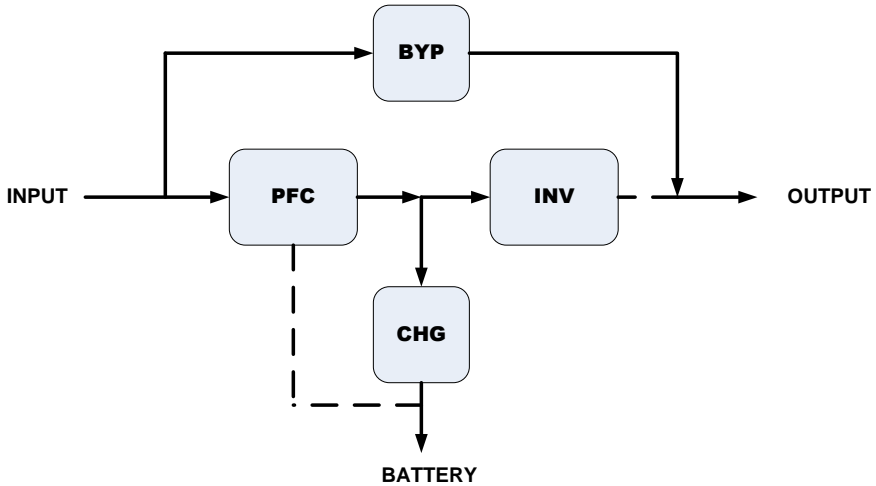

Fig 1- 7: ECO Mode

### Frequency Converter Mode

In this mode, input and output nominal frequency is different, and the bypass is forbidden to use.

---

#### NOTICE

- ***If overload timeout, UPS will shutdown output.***
- ***The load should be derated to 50% and below.***

---

### Self Aging Mode

If users want to burn in UPS without load, could set the UPS as **Self Aging Mode**, in this mode, the current flow through rectifier, inverter, and back to input through bypass. It needs only 5% loss to burn in UPS with 100% load. Shown as Fig 1-8.

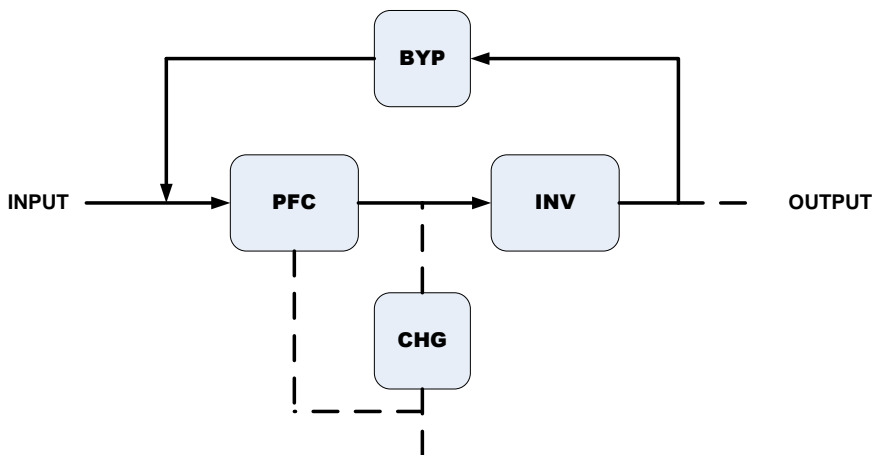

Fig 1- 8: Self Aging Mode

## 1.7 Electrical Specification

### 1. General Specification

Model	6KB	6KL	10KB	10KL	3/1 10KL	3/1 15KL	3/1 20KL
Power Rating	6KVA/6KW		10KVA/10KW		10KVA/10KW	20KVA/20KW	20KVA/20KW
Frequency (Hz)	50/60		50/60		50/60	50/60	50/60
Input	Voltage	(176-288)VAC	(176-288)VAC		(305-407)VAC	(305-407)VAC	(305-407)VAC
	Current	36A max.	60A max		19/19/19A max	29/29/29A max	38/38/38A max
Battery	Voltage	192VDC	192VDC		192VDC	192VDC	192VDC
	Current	40A max	62A max		62A max	94A max	125A max
Output	Voltage	220/230/240	220/230/240		220/230/240	220/230/240	220/230/240
	Current	27/26/25A	45/43/42A		45/43/42A	67/65/63A	90/86/84A
Efficiency	95.5% max		95.5% max		95.5% max	95.5% max	95.5% max
Dimension (WxDxH) mm	190*495*338 190*495*550		190*495*338 190*495*550		190*514*497		

### 2. Electrical Performance

Input			
Model	Voltage	Frequency	Power Factor

UPS	Single-phase	40-70Hz	>0.99(Full load)
-----	--------------	---------	------------------

Output					
Voltage Regulation	Power Factor	Frequency tolerance.	Distortion	Overload capacity	Crest ratio
±1%	1	±0.1	THD<1% Full load (Linear Load)	105%~110%: 10mins 111%~125%: 1 min 126%~150%: 30 seconds	3:1 maximum

### 3. Operating Environment

Temperature	Humidity	Altitude	Storage temperature
0°C-40°C	<95%	<1000m	0°C-70°C

## NOTICE

***If the UPS is installed or used in a place where the altitude is above than 1000m, the output power must be derated according to IEC standard.***

---

---

## 2. Installation

The system should be installed and wired only by qualified electricians in accordance with applicable safety regulations.

### 2.1 Unpacking and Inspection

- 1) Unpack the packaging and check the package contents. The shipping package contains:
  - UPS
  - 1 user manual
- 2) Check the appearance of the UPS to see if there is any damage during transportation. Do not turn on the unit and notify the carrier and dealer immediately if there is any damage or lacking of some parts.

### 2.2 Connect AC Power Cables

Recommended size of cables is shown as below:

Rated power	AC input	AC output	Battery
6KVA	UL1015 12AWG	UL1015 12AWG	UL1015 12AWG
10KVA	UL1015 10AWG	UL1015 10AWG	UL1015 10AWG
	Input breaker	Output breaker	Battery breaker
6KVA	40A	40A	40A
10KVA	63A	63A	80A
Rated power	AC input	AC output	Battery
3/1 10KVA	UL1015 14AWG	UL1015 10AWG	UL1015 10AWG
3/1 15KVA	UL1015 12AWG	UL1015 8AWG	UL1015 8AWG
3/1 20KVA	UL1015 10AWG	UL1015 6AWG	UL1015 6AWG
	Input breaker	Output breaker	Battery breaker
3/1 10KVA	32A	63A	80A
3/1 15KVA	40A	80A	100A
3/1 20KVA	50A	125A	125A

---

## NOTICE

***For the long backup time modes, make sure that the capacity of batteries is larger than 38AH to avoid over charging. If not, please confirm the charge current and set the charge current is smaller than 0.2\*AH.***

---

## NOTICE

---

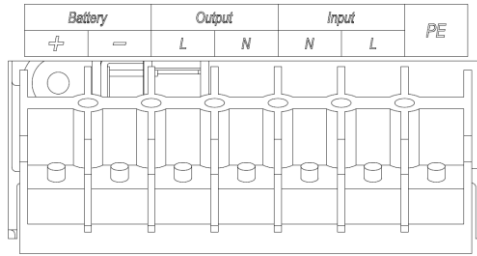

Single phase models

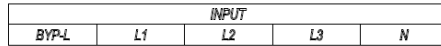
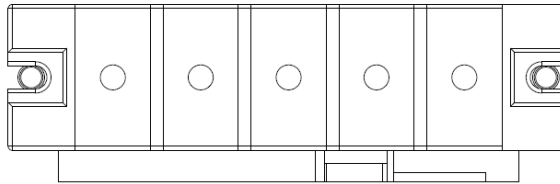
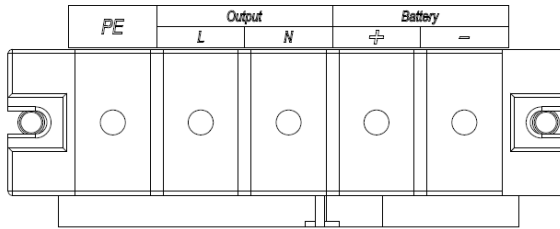

3/1 models

Fig 2- 1: Terminal Block Wiring Diagram

- 1) Recover the cover of terminal on the rear panel
- 2) Connect input and output cables as Fig 2-5

## NOTICE

**Connect an AC breaker between output and load to protect UPS from interrupt of load fail.**

### 2.3 Connect the long backup time model UPS with the external battery

- 1) Assemble battery cables with shipping terminals.
- 2) Connect an DC breaker between UPS and battery cabinet.
- 3) Open DC breaker before connect battery cables to UPS.
- 4) Connect battery cables to UPS terminal as Fig 2-5.

---

---

## 2.4 Connect Parallel Cables

### Parallel installation

- 1) Users need to opt two standard DB15 communication cables.
- 2) Connect input cables of each UPS with an independent AC breaker as Fig 2-6.
- 3) Connect the output wires of each UPS to an output breaker.
- 4) Please select suitable breaker according to input, output and battery current.

## NOTICE

The requirement of the output cables is as follows:

- It's recommended that the cables of output of the UPS to be less than 20m.
- The difference between the cables of input & output of the UPSs is required to be less than 10%.

The wiring diagram is shown as follows:

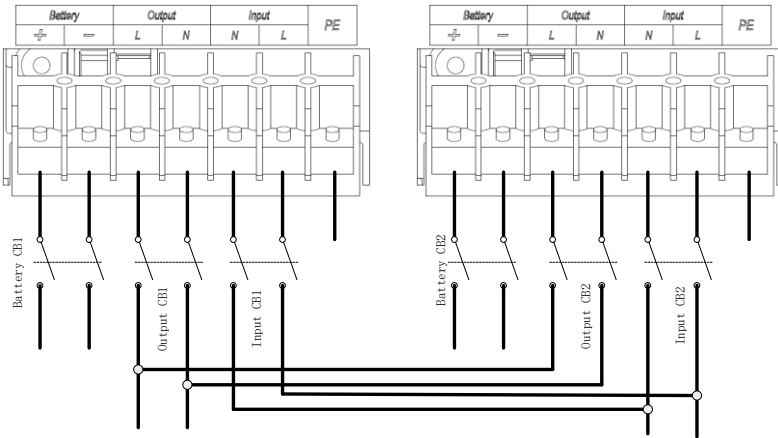

Single phase models

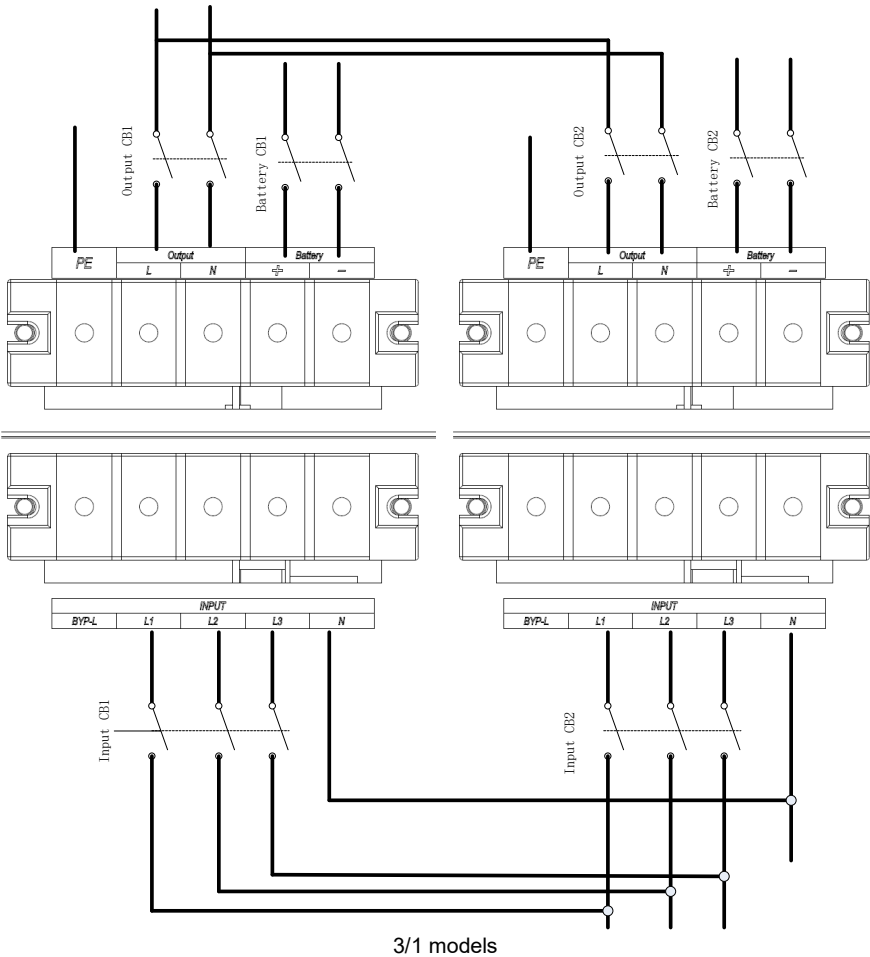

Fig 2- 2: Parallel Wiring Diagram

## 2.5 Connect Communication Cables

Communication cable includes: USB cable and parallel communication cables.

Connect USB cable:

- 1) Connect USB cable to USB port at the back panel of UPS shown as Fig 1-2
- 2) Connect USB cable to PCB

Connect communication cables:

If there are two UPS are paralleled, connect communication cables as Fig.2-7

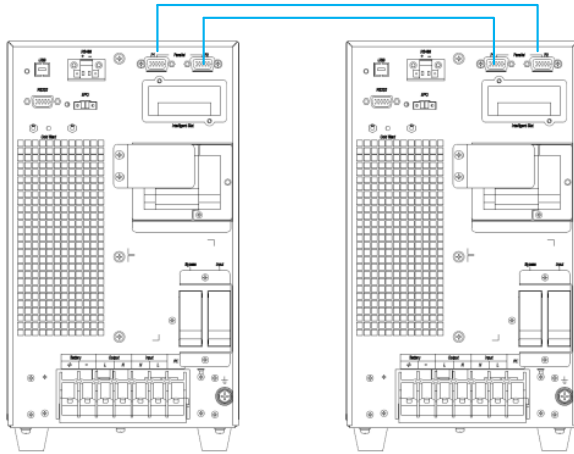

Fig 2- 3: 2 UPS Paralleled System

If there are 3 or more UPS are paralleled, connect communication cables as Fig 2-8

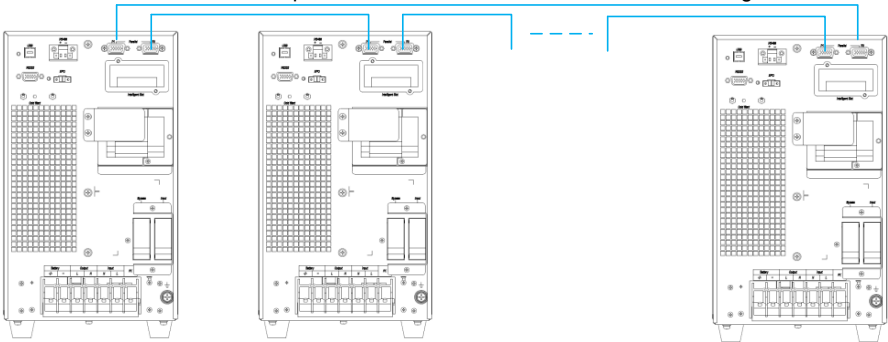

Fig 2- 4: 3 UPS Paralleled System

## NOTICE

**Must set the UPS is parallel system as “parallel mode” via software according to “Annex A” before start parallel system**

### 3. Controls And Indicators

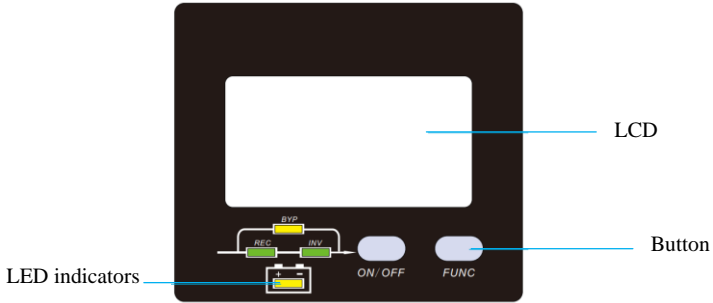

Fig 3- 1: Display Panel

#### 3.1 Description of Panel

Controls	Description
ON/OFF	Press ON/OFF to cold start UPS from battery Press ON/OFF for 2.5s to shut down inverter and transfer to bypass Press ON/OFF for 2.5s to shut down UPS completely when UPS is in battery mode Press ON/OFF to confirm setting when in setting mode
FUNC	Press FUNC to page down to check LCD menu Press FUNC for 2.5s at the page 1 to mute off, press again to mute on Press FUNC and ON/OFF together for 2.5s to enter in setting mode Press FUNC for 2.5s at the P4 to fault clear
Indicators	Description
REC	Rectifier indicator: green--rectifier is normal, green flicker--rectifier is starting, dark—rectifier is not working
INV	Inverter indicator: green--inverter is normal, green flicker--inverter is starting or tracking with bypass(ECO), dark—inverter is not working
BYP	Bypass indicator: yellow—bypass is normal, yellow flicker—bypass alarm ,dark—UPS is in normal mode and bypass is normal
BAT	Battery indicator: yellow—battery discharged, yellow flicker—No battery or battery alarm, dark—battery is connected

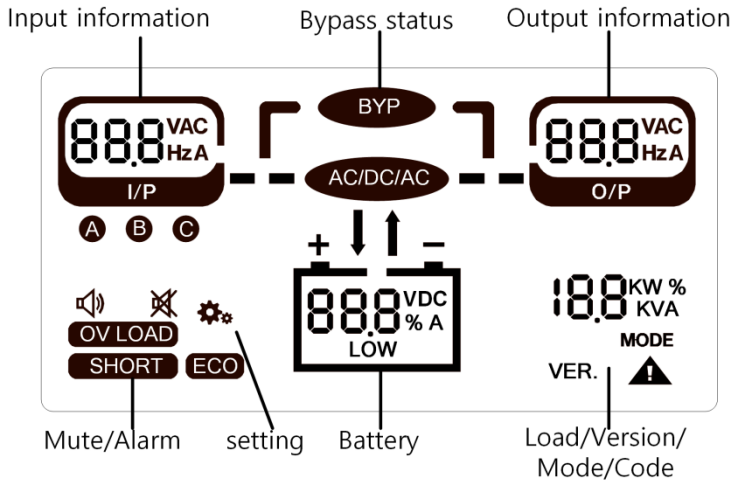

Fig 3- 2: LCD Menu

### 3.2 Description of LCD Menu

Menu	Information
Input information	Main input: voltage VAC, current A, frequency Hz, "A,B,C" display in turn for phase A,B,C Bypass input (bypass "B" flicks): Voltage VAC, current A, frequency Hz
Battery information	Battery: voltage VDC, discharge/charger current A, remained capacity %, battery low alarm LOW!
Output information	Output information: Voltage, current, frequency
Alarm	🔇 🔊 : mute on/off OV LOAD! : over load SHORT: output short ECO: working in ECO mode
Load/Version/Code	Load: active load KW, apparent load KVA, load percent % VER: firmware version MODE: system mode, S-single mode, P-parallel mode, E-ECO mode, A-self aging mode

Menu	Information
	⚠ : warning code, refer to “7. Trouble Shooting” to get detailed code list
Others	SETTING: LCD is in setting mode BYPASS: bypass conversion

Press **FUNC** to check menu:

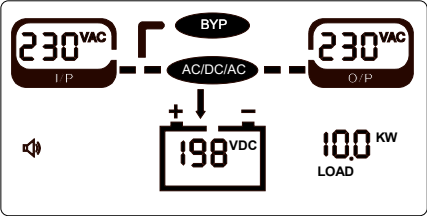
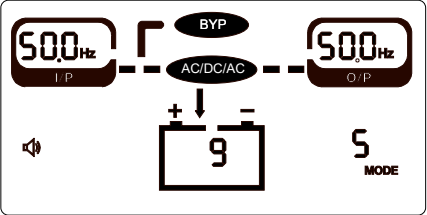
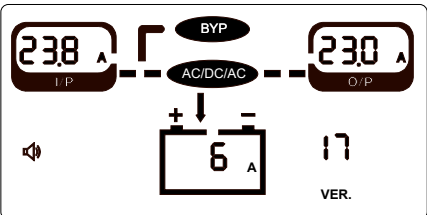
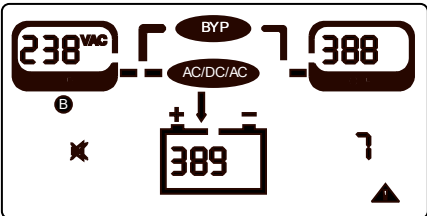
Page	details
	<p>P1:  INPUT voltage: 230VAC,  OUTPUT voltage: 230VAC  Battery voltage: 198VDC  LOAD: 10KW  Load percent (%), active power(KW),  apparent power(KVA) are displayed in turn  Press “FUNC” for 2.5s in this page to mute off</p>
	<p>P2:  INPUT frequency: 50Hz  OUTPUT frequency: 50Hz  Battery AH: 9AH.  If remained capacity is set available, AH and  remained capacity (%) are displayed in turn  System MODE: S-single unit</p>
	<p>P3:  INPUT current: 23.8A  OUTPUT current: 23A  Battery current: 6A (downwards arrow:  charge, upwards arrow: discharge, no arrow:  no battery)  Firmware Version: VER. V1.017 for example,  1 and 17 display in turn</p>
	<p>P4:  “B”: flicks, bypass input menu now  Bypass INPUT voltage: 220VAC  BUS+ voltage:388VDC  BUS- voltage:389VDC  ⚠ alarm code: 07  Press “FUNC” for 2.5s to manually fault clear</p>

### 3.3 Setting

If want to set rated parameters, press ON/OFF and FUNC buttons together for 2.5s to enter in setting mode, "SETTING" on the bottom of LCD present and all LEDs flicks, LCD displays current setting in turn.

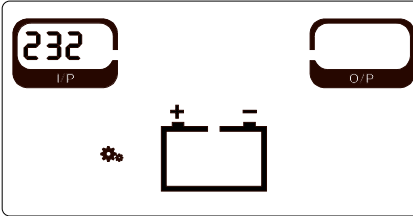
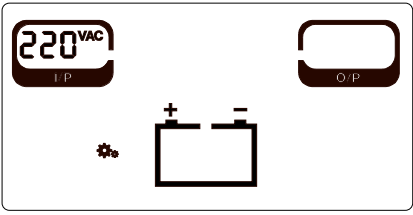
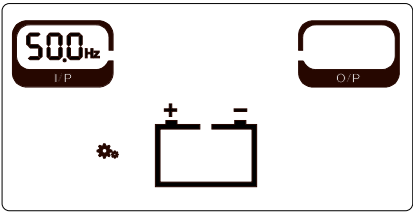
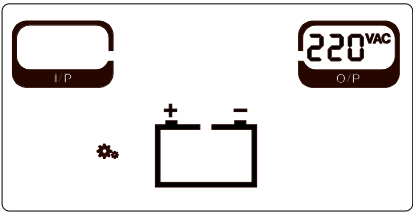
<p>Main page</p>	<p>Press "FUNC" to select setting menu, press "ON/OFF" to confirm selection and enter in setting.          123—rated setting          232—RS232 setting          345—SNMP card          485—485 setting          567—setting recovery</p>	
<p>Input rated voltage setting</p>	<p>Could select input voltage as          110VAC/115VAC/120VAC/200VAC/ 208VAC/          220VAC/ 230VAC/          240VAC, press FUNC to select, press ON/OFF to confirm selection and enter in next page</p>	
<p>Input rated frequency setting</p>	<p>Could select input frequency as          50Hz/60Hz, press FUNC to select, press ON/OFF to confirm selection and enter in next page</p>	
<p>Output rated voltage setting</p>	<p>Could select output voltage as          110VAC/115VAC/120VAC/200VAC/ 208VAC/          220VAC/ 230VAC/          240VAC, press FUNC to select, press ON/OFF to confirm selection and</p>	

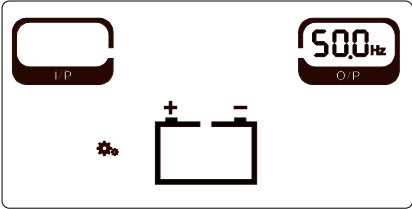
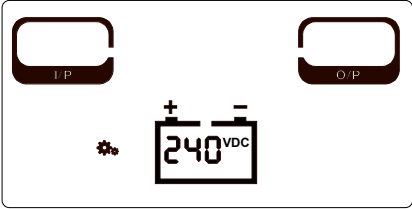
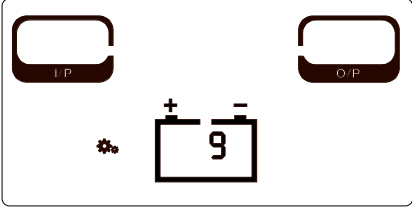
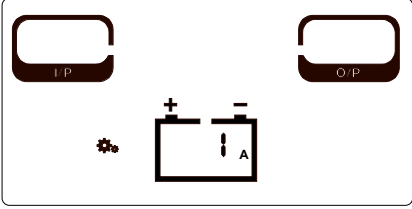
	enter in next page	
Output rated frequency setting	Could select output frequency as 50Hz/60Hz, press FUNC to select, press ON/OFF to confirm selection and enter in next page	
Battery number setting	Could select battery number as 10(120VDC)/12(144VDC)/16blocks (192VDC)/18 blocks(216VDC)/20 blocks (240VDC), press FUNC to select, press ON/OFF to enter in next page	
Battery capacity setting	Select battery AH according to site application, press FUNC to select, press ON/OFF to confirm selection and enter in next page	
Charger current setting	Charger current could be set as below: Standard model: 1A Long backup model: 1,2,3,4,5,6,7,8A Press FUNC to select, press ON/OFF to confirm and enter in next page	

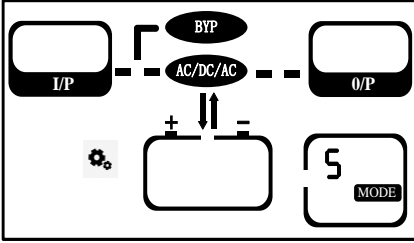
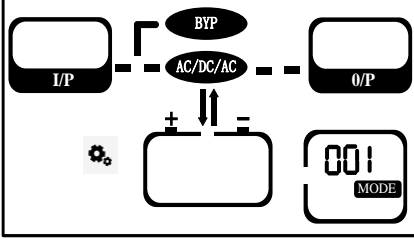
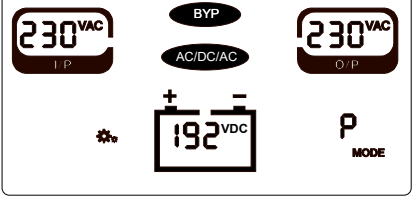
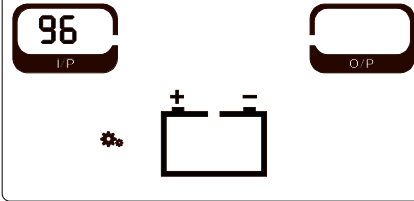
<p>System mode</p>	<p>S-single mode  P-parallel mode  E-ECO mode  A-self aging mode  Press FUNC to select,  press ON/OFF to confirm  and enter in next page.</p>	
	<p>001- parallel ID1  In parallel mode, the  parallel ID could be set  as 000 to 008  Press FUNC to select,  press ON/OFF to confirm  and enter in next page.</p>	
<p>Exit</p>	<p>If all settings are  finished, settings will be  displayed on LCD, press  ON/OFF to exit. The  setting will be activated  after restart UPS.</p>	
<p>Communication  protocol setting</p>	<p>Select 232, 240 or 485 at  main page to set  communication:  Baud rate:96—9600,  12—1200,  24—2400,48—4800,192  --19200  Press "ON/OFF" to  confirm and enter in ID  setting</p>	

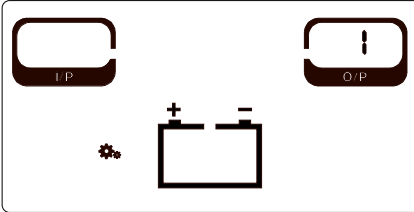
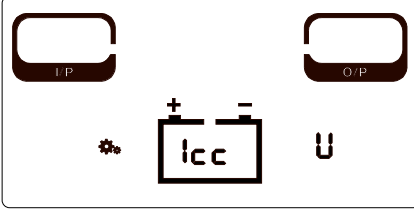
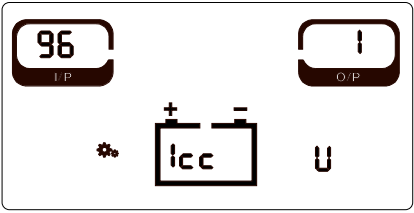
<p>Communication ID setting</p>	<p>Set ID as 1 to 32. Press "ON/OFF" to confirm and enter in protocol setting</p>	
<p>Communication protocol setting</p>	<p>0cc--ModBus 1cc--RTU 2cc—NetAgent Press "ON/OFF" to confirm and finish communication setting</p>	
<p>Exit setting</p>	<p>If all settings are finished, settings will be displayed on LCD, press ON/OFF to exit. The setting will be activated after restart UPS.</p>	

 **NOTE**

**Press "FUNC" and "ON/OFF" at any setting page for 2.5s to exit setting mode.**

---

---

## 4. Operation

### 4.1 Operation Mode

#### 4.1.1 Turn on the UPS

- 1) Close the battery breaker (long backup model), close the main input and bypass input breaker.
- 2) UPS starts automatically, after about 1 minute, UPS works at normal mode.
- 3) Connect loads one by one to UPS.

#### 4.1.2 Turn off the UPS at normal mode

- 1) Shutdown the connected load and open external output breaker
- 2) Press ON/OFF button for 2.5S to transfer to bypass.
- 3) Open the mains input breaker and bypass input breaker. For long backup model, open the battery breaker to turn off UPS completely.
- 4) For standard model, press ON/OFF for 2.5S then to shutdown completely.

#### 4.1.3 Turn on the UPS from battery

- 1) Make sure the battery is correctly connected.
- 2) Press “Cold start” button on the rear panel until LCD is on and buzzer alarms.
- 3) UPS starts from battery automatically after about 1minutes. If set as “manual start”, please press “FUNC” to start.

#### 4.1.4 Turn off the UPS at Battery mode

- 1) Press ON/OFF for 2.5S to shutdown. Then open external battery breaker.
- 2) Wait for a moment, the UPS will shutdown completely.

---

## NOTICE

- ***Please turn off the connected loads UPS is normal ready and turn on the loads one by one after the UPS is working at normal mode. Turn off all of the connected loads before turning off the UPS.***
- ***If press “cold start” button once was useless, please press it twice quickly to turn on UPS.***

---

## WARNING

***Internal DC bus still has hazardous high voltage in several minutes, please wait for at least 5 minutes to open UPS. And check the DC bus voltage before maintenance.***

---

### 4.2 Parallel Operation

#### 4.2.1 Turn on the UPSs of Parallel System

Make sure the power cables and communication cables are correctly.

- 1) Close external output CB1 and CB2
- 2) Turn on UPS1. Then turn on UPS2.
- 3) Close external battery breakers
- 4) Turn on loads one by one

#### 4.2.2 Turn off Parallel System

- 
- 1) Turn off the connected load. Press ON/OFF button to transfer to bypass. Open output breakers. Open mains input and bypass input breakers of all UPSs.
  - 2) For long backup model, open external battery breakers. After a few seconds, the UPSs will shutdown completely.

#### **4.2.2 How to remove a single UPS from the parallel system:**

- 1) If you need to remove one UPS of the UPSs parallel system which is in normal mode, open input/output/battery breaker to shutdown the UPS firstly.
- 2) Remove the parallel cables of the UPS that need to be removed. Then connect remained parallel cables back to remained parallel system.
- 3) Disconnect all cables of removed UPS and remove it.

## 5. Control and Communication

UPS includes several communication ports: RS232, EPO, SNMP card, USB, dry contact, RS485.

**NOTICE:** Only one of SNMP card, dry contact can be installed at the same time. Only one of RS232 and USB is available at the same time.

### 5.1 SNMP Card

SNMP card is used to monitor the UPS via TCP/IP, user can check the UPS status, voltage and current on the internet. Please refer to the user manual of SNMP card to get more detailed information.

### 5.2 Dry Contact

There are two types of dry contact for option: DB9, phoenix terminal.

Max output current for dry contact is 1A. The function of dry contact is listed as *Fig 5-1*:

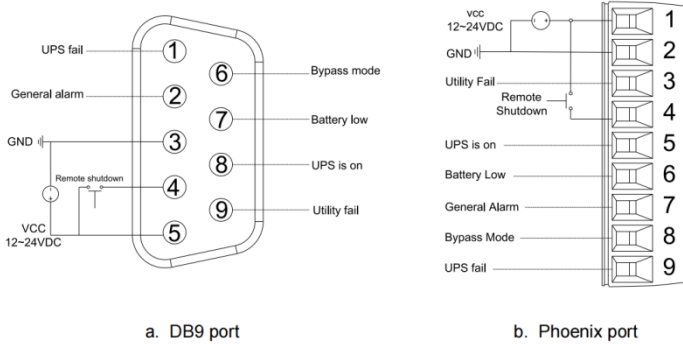

Fig 5- 1: Dry Contact

Table 5- 1: Function of Dry Contact

Port PIN / Function	DB9	Phoenix	Description
UPS fail	1	9	Pin9 to pin1 is NO (Normally Open) if something is failure in UPS. If not, NC (Normally Close)
General alarm	2	7	Pin7 to pin1 is NO if something is abnormal. If not, NC
GND	3	2	External power supply GND
Remote shutdown	4	4	UPS shutdowns rectifier and inverter if utility is normal. UPS shutdowns completely if in battery mode. Close

			switch to activate.
Power supply	5	1	External power supply.12VDC~24VDC, Common connection.
Bypass mode	6	8	Pin8 to pin1 is NC if UPS works in bypass mode. If not, NO.
Battery low	7	6	Pin6 to pin1 is NO if battery voltage is low. If not, NC.
Normal mode	8	5	Pin5 to pin1 is NC if UPS works in normal mode. If not, NO.
Utility fail	9	3	Pin3 to pin1 is NO if utility is failure. If not, NC.

### 5.3 EPO

The remoted EPO is located on the rear panel of UPS shown as Fig 1-2. It's normal closed, if it's opened, it will activate EPO function, the UPS will be shutdown.

**NOTE: The system EPO doesn't work as default, please set it via software if needed.**

---

---

## 6. Maintenance

### 6.1 Battery Maintenance

The batteries used in standard models are value regulated, sealed lead-acid, maintenance free battery. When being connected to the utility power, whether the UPS is turned on or not, the UPS keeps charging the batteries.

- 1) The UPS should be charged once every 4 to 6 months if it has not been used for a long time.
- 2) In the regions of hot climates, the battery should be charged and discharged every 2 months. The standard charging time should be at least 12 hours.
- 3) At normal conditions, the battery life lasts 3 to 5 years. In case if the battery is abnormal, earlier replacement should be made.
- 4) Battery replacement should be performed by qualified personnel.
- 5) Replace batteries with the same number and same type of batteries.
- 6) All the batteries should be replaced at the same time.

### 6.2 Battery Disposal

- 1) Before disposing of batteries, remove jewelry, watches and other metal objects.
- 2) Use rubber gloves and boots, use tools with insulated handles.
- 3) If it is necessary to replace any connection cables, please purchase the original materials from the authorized distributors or service centers, so as to avoid overheat or spark resulting in fire due to insufficient capacity.
- 4) Do not dispose of batteries or battery packs in a fire. The batteries may explode.
- 5) Do not open or mutilate batteries, released electrolyte is highly poisonous and harmful to the skin and eyes.
- 6) Do not short the positive and negative of the battery electrode, otherwise, it may result in electric shock or fire.
- 7) Make sure that there is no voltage before touching the batteries. The battery circuit is not isolated from the input potential circuit. There may be hazardous voltage between the battery terminals and the ground.
- 8) Even though the input breaker is disconnected, the components inside the UPS are still connected with the batteries, and there are potential hazardous voltages. Therefore, before any maintenance and repairs work is carried out, switch off the breaker of the battery pack or disconnect the jumper wire of connecting between the batteries.
- 9) Batteries contain hazardous voltage and current. Battery maintenance such as the battery replacement must be carried out by qualified personnel who are knowledgeable about batteries. No other persons should handle the batteries

### 6.3 Battery Replacement Procedures

- 1) Transfer to bypass mode
- 2) Close the manual bypass breaker. Open input, output and battery breaker to shutdown UPS. If no manual bypass breaker, please shutdown UPS completely.
- 3) Remove both side panels
- 4) Disconnect battery cables one by one.
- 5) Remove fasten kit of battery and then take out batteries one by one.
- 6) Assemble new batteries and connect cables back as follow. Then transfer the UPS back to normal mode.

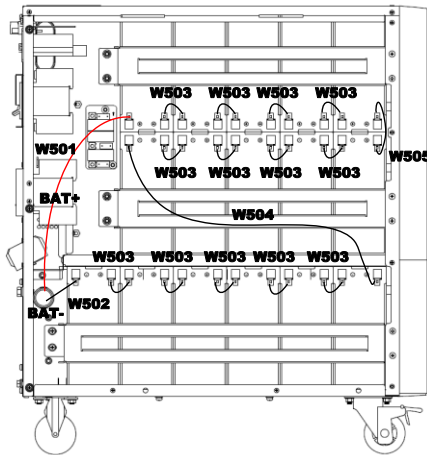

16 blocks of batteries

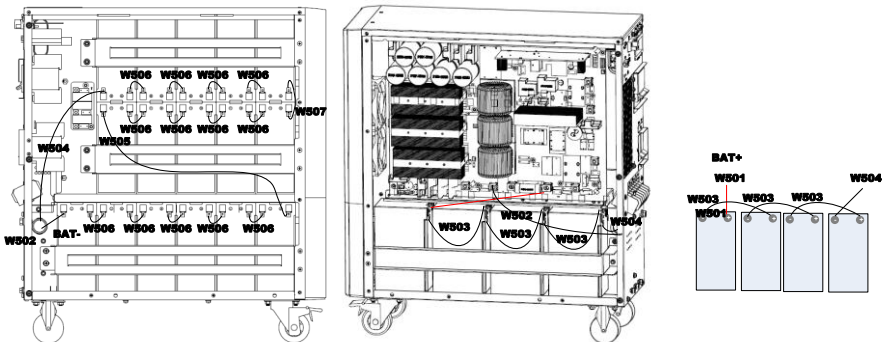

20 blocks of batteries

### 6.4 Checking UPS status

It is recommended to check the UPS once every half year.

---

Check if the UPS is faulty: Are the LED indicators abnormal? Is there any alarm?

Check if the UPS is working in bypass mode: Normally, the UPS works at normal mode, if it's working in bypass mode, please check: overload, internal fault and so on.

Check if the battery is discharging: When the mains input is normal, the battery should not discharge, if the UPS is working at battery mode, please check: if mains input is failure, battery test, operator intervention and so on.

Check if the ventilation of UPS is blocked: If blocked, please clear it to make sure the UPS is normally working.

## 7. Trouble Shooting

If UPS alarms and buzzer sound, please press “FUNC” to get alarm code on the menu of alarm code (page ) on LCD. **And press “FUNC” for 2.5s when at page 4 to manually fault clear.** If alarms are still existent, please check the problem follow the *Table 7-1*:

Code	Cause	Solution
1	No battery	<ul style="list-style-type: none"> <li>● Check if the battery cables are connected correctly</li> <li>● Check battery breaker or fuses are opened</li> <li>● Check if batteries are damaged</li> </ul>
2	EPO	<ul style="list-style-type: none"> <li>● Check if EPO is closed correctly</li> <li>● Check if EPO is activated manually</li> </ul>
3	Inverter on less	Available ups capacity is less then the load capacity. Please reduce the load capacity or make sure that the UPS capacity is big enough.
4	Utility abnormal	UPS mains input is abnormal. <ul style="list-style-type: none"> <li>● Check if mains input is normal</li> <li>● Check if mains input voltage and frequency is over the working range</li> <li>● Check if mains input breaker or external input breaker is opened</li> <li>● Check if the input phase sequence against</li> </ul> Please recover mains input power, otherwise output will be shutdown if battery is discharged to EOD
5	Line neutral wires reversed	Input Line and neutral is reversed. Check the polarity of line wire and neutral wire.
6	Bypass abnormal	<ul style="list-style-type: none"> <li>● Check if bypass input power is abnormal</li> <li>● Check if bypass input breaker is opened</li> </ul> Please recover bypass input power, otherwise there will be no backup circuit when UPS is faulty
7	Bypass fault	Bypass SCR is opened or shorted, please contact with local dealer
8	Bypass overload	Check the load and remove some non critical load until the load is below 95%
9	Bypass overload timeout	Bypass overload and timeout, UPS will shutdown output
10	Over transfer times	Mains and battery or inverter and bypass transfer for 5 times in 1hour
11	Output short circuit	Load is abnormal or output breaker is failure. <ul style="list-style-type: none"> <li>● Check if load is abnormal and the faulty load is shutdown</li> <li>● Check if output breaker is failure</li> </ul>

		If the abnormal load is removed, please manually fault clear to restart UPS.
12	End of discharge	UPS works in battery mode for long time after utility failure. UPS output will be off until utility power is on. Please save your data when UPS alarm "utility fail"
13	Battery self-detect fault	UPS transfer to battery mode for 20 seconds to check if batteries are normal Please check the battery cables connect.
14	Rectifier fault	DC bus over voltage, low voltage, shorted or IGBT opened. Please manually clear the fault and if the fault is still on, please contact with local dealer
15	Inverter fault	Inverter voltage is abnormal, or inverter IGBT opened. Please manually clear the fault and if the fault is still on, please contact with local dealer
16	Rectifier over temperature	Rectifier heatsink is over temperature or the temp sensor is not connected correctly. <ul style="list-style-type: none"> <li>● Check if fans are working normally</li> <li>● Check if any thing block ventilation</li> <li>● Check if the sensor is connected correctly</li> <li>● Check if the environmental temp is over the range of UPS</li> </ul>
17	Fan fault	One or more fans are faulty or blocked Check if all fans working normally Check if something blocks fan
18	Overload	Inverter is overload. Please remove numbers of non critical loads, or else UPS could transfer to bypass
19	Over load timeout	UPS will transfer to bypass and if bypass overload, output could be shutdown caused by bypass overload timeout. Please remove numbers of loads and the UPS will transfer back to inverter
20	Inverter over temperature	Inverter heat sink is over temperature or the temp sensor is not connected correctly. Check if fans are working normally Check if any thin block ventilation Check if the sensor is connected correctly Check if the environmental temp is over the range of UPS
21	Battery low	Remained battery capacity is low when in battery mode
22	Input natural line lost	Input natural line disconnect. Please check the input cables connect.
23	Bypass fan fault	One or more fans are failure, fan wires are loosen

		Please contact with distributor or service center.
24	Manual shutdown	UPS will shutdown output or transfer to bypass mode.
25	Charger fault	There is no charger output. Please contact with distributor or service center.
26	EOD system inhibited	System is inhibited to supply after the battery is EOD (end of discharging)
27	Input over current	Abnormal large current enter in rectifier. Please contact with distributor or service center.
31	On UPS Inhibited	Inhibit system transfer from bypass to UPS (inverter). Check: Whether the power module's capacity is big enough for load. Whether the rectifier is ready. Whether the bypass voltage is normal.
32	Relay open	Inverter relay is opened. Please contact with local dealer.
33	Relay short	Inverter relay is closed. Please contact with local dealer.
34	Inverter protect	Inverter voltage abnormal or DC bus is over voltage. UPS will fault clear automatically. If not, please contact with local dealer
35	Parallel cables error	Check if all parallel communication cables are connected correctly
36	Synchronization pulse lost	Parallel cables disconnect or parallel board setting abnormal. Please check the parallel cables and parallel board jump setting.
37	Current unbalance fail	Parallel system, the output current between the UPS unbalance. Please check each UPS output load capacity.
38	Input Current Unbalance	The difference of input current between every two phases is over 40% of rated current. Please check if rectifier's fuses, diode, IGBT or PFC diodes are broken. Please check if input voltage is abnormal.
39	Maintenance CB Closed	Manual maintenance breaker is closed
40	Over synchronization	Bypass voltage or frequency is over tracking range. There could be interruption if manually transfer to bypass or inverter is faulty
41	Battery Test	System transfer to battery mode for 20 seconds to check if batteries are normal
42	Battery Maintenance	System transfer to battery mode until battery voltage is down to 1.1*EOD voltage to maintain battery string
43	Battery Maintenance Fail	Check If UPS is normal and not any alarms

---

---

		If the battery voltage is over 90% of float voltage If load is over 25%
44	Manual bypass on	Manual bypass is closed, the UPS will transfer to bypass and forbidden to transfer back to inverter
45	Battery reversed	Check if battery cables are connected correctly Check if inverter cables of battery packs are connected correctly

---

## Annex A. Parallel Setting

1. Under system settings, set "System Mode" -- "parallel", if have 3 cabinet parallel, setting the UPS number to "3", and if only 2 UPS to "2". Cabinet ID can be set from 0 to "n-1", "n" is the number of parallel. Ensure there are no duplicate ID settings in the parallel system.
2. Each UPS in the parallel system is set in the same setting mode, and sets the cabinet ID.



The screenshot shows a web-based configuration interface for a UPS system. At the top, there are navigation tabs: "System Setting" (highlighted in green), "Rate setting", "Syncodel", "Syncode2", and "Dry contact". Below the tabs, the "System Mode" is set to "Parallel", with a dropdown menu also showing "Parallel". The "UPS number" is set to "3". Below this, the "Cabinet ID" is set to "1", and the "Adjust output voltage" is set to "220". There are input fields for each of these values.

4. After setting, turn on the system.

**Annex B. Mechanical Dimension**

**6KL/10KL**

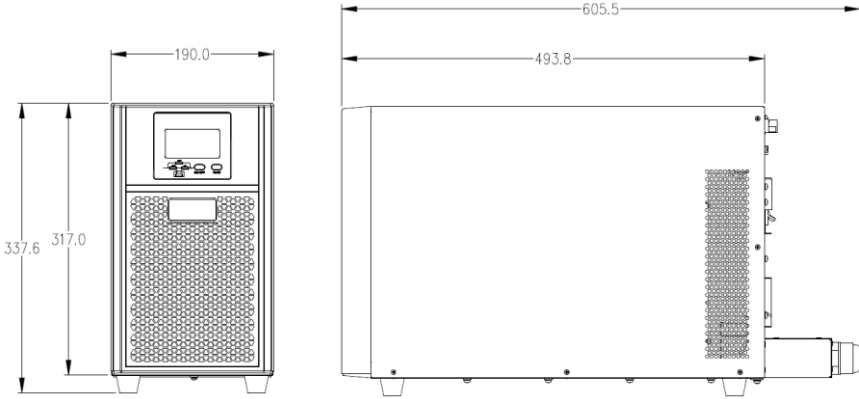

**6KB/10KB**

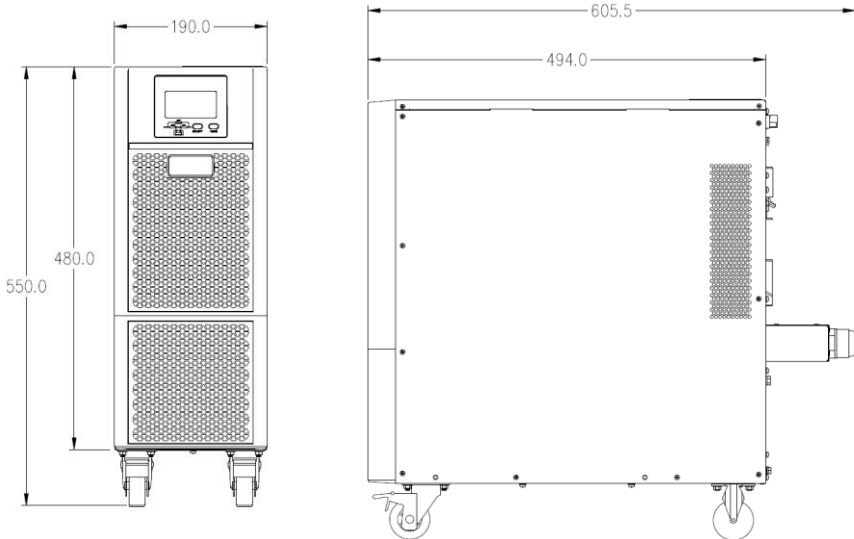

**3/1 10KL/15KL/20KL**

